

Cams

Cams

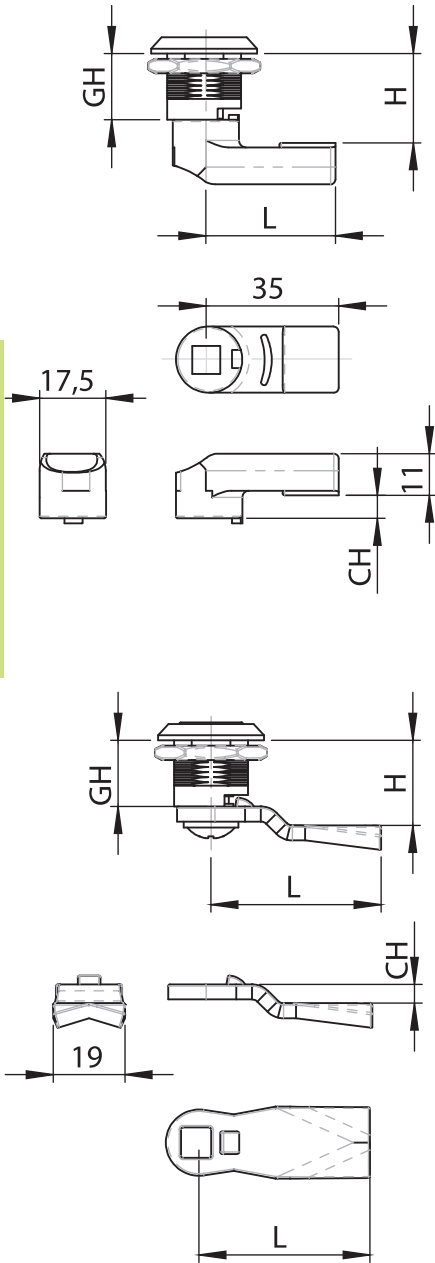

| Table 1 | Item Number | XXX | CH (mm) | L (mm) | GH=13,5 H(mm) |
|---------|-------------|------|---------|--------|---------------|
| | 1900 - 604 | 604 | -6 | 24 | 7,5 |
| | 1900 - 602 | 602 | 0 | 24 | 13,5 |
| | 1900 - 605S | 605S | 1,5 | 30 | 15 |
| | 1900 - 603 | 603 | 6 | 24 | 19,5 |

| Table 2 | Item Number | XXX | CH (mm) | L (mm) | GH=13,5 H(mm) |
|---------|-------------|------|---------|--------|---------------|
| | 1900 - 704 | 704 | -6 | 24 | 7,5 |
| | 1900 - 702 | 702 | 0 | 24 | 13,5 |
| | 1900 - 705S | 705S | 1,5 | 30 | 15 |
| | 1900 - 703 | 703 | 6 | 24 | 19,5 |

| Table 3 | Item Number | XXX | CH (mm) | L (mm) | GH=15 H(mm) | GH=18 H(mm) | GH=20 H(mm) | GH=30 H(mm) | GH=40 H(mm) | GH=50 H(mm) | GH=60 H(mm) |
|---------|-------------|-----|---------|--------|-------------|-------------|-------------|-------------|-------------|-------------|-------------|
| | 1900 - 101 | 101 | 0 | 35 | 15 | 18 | 20 | 30 | 40 | 50 | 60 |
| | 1900 - 102 | 102 | 4 | 35 | 19 | 22 | 24 | 34 | 44 | 54 | 64 |
| | 1900 - 104 | 104 | 4 | 40 | 19 | 22 | 24 | 34 | 44 | 54 | 64 |
| | 1900 - 103 | 103 | 6 | 35 | 21 | 24 | 26 | 36 | 46 | 56 | 66 |
| | 1900 - 105 | 105 | 6 | 40 | 21 | 24 | 26 | 36 | 46 | 56 | 66 |

| Table 4 | Item Number | XXX | CH (mm) | L (mm) | GH=15 H(mm) | GH=18 H(mm) | GH=20 H(mm) | GH=30 H(mm) | GH=40 H(mm) | GH=50 H(mm) | GH=60 H(mm) |
|---------|-------------|-----|---------|--------|-------------|-------------|-------------|-------------|-------------|-------------|-------------|
| | 1900 - 316 | 316 | -2 | 35 | 13 | 16 | 18 | 28 | 38 | 48 | 58 |
| | 1900 - 318 | 318 | 0 | 35 | 15 | 18 | 20 | 30 | 40 | 50 | 60 |
| | 1900 - 320 | 320 | 2 | 35 | 17 | 20 | 22 | 32 | 42 | 52 | 62 |
| | 1900 - 322 | 322 | 4 | 35 | 19 | 22 | 24 | 34 | 44 | 54 | 64 |
| | 1900 - 324 | 324 | 6 | 35 | 21 | 24 | 26 | 36 | 46 | 56 | 66 |
| | 1900 - 325 | 325 | 7 | 35 | 22 | 25 | 27 | 37 | 47 | 57 | 67 |
| | 1900 - 326 | 326 | 8 | 35 | 23 | 26 | 28 | 38 | 48 | 58 | 68 |
| | 1900 - 328 | 328 | 10 | 35 | 25 | 28 | 30 | 40 | 50 | 60 | 70 |
| | 1900 - 330 | 330 | 12 | 35 | 27 | 30 | 32 | 42 | 52 | 62 | 72 |

| Table 5 | Item Number | XXX | CH (mm) | L (mm) | GH=15 H(mm) | GH=18 H(mm) | GH=20 H(mm) | GH=30 H(mm) | GH=40 H(mm) | GH=50 H(mm) | GH=60 H(mm) |
|------------|-------------|-----|---------|--------|-------------|-------------|-------------|-------------|-------------|-------------|-------------|
| | 1900 - 204 | 204 | -14 | 45 | 1 | 4 | 6 | 16 | 26 | 36 | 46 |
| | 1900 - 206 | 206 | -12 | 45 | 3 | 6 | 8 | 18 | 28 | 38 | 48 |
| | 1900 - 210 | 210 | -8 | 45 | 7 | 10 | 12 | 22 | 32 | 42 | 52 |
| | 1900 - 212 | 212 | -6 | 45 | 9 | 12 | 14 | 24 | 34 | 44 | 54 |
| | 1900 - 214 | 214 | -4 | 45 | 11 | 14 | 16 | 26 | 36 | 46 | 56 |
| | 1900 - 218 | 218 | 0 | 45 | 15 | 18 | 20 | 30 | 40 | 50 | 60 |
| | 1900 - 220 | 220 | 2 | 45 | 17 | 20 | 22 | 32 | 42 | 52 | 62 |
| | 1900 - 222 | 222 | 4 | 45 | 19 | 22 | 24 | 34 | 44 | 54 | 64 |
| | 1900 - 224 | 224 | 6 | 45 | 21 | 24 | 26 | 36 | 46 | 56 | 66 |
| | 1900 - 225 | 225 | 7 | 45 | 22 | 25 | 27 | 37 | 47 | 57 | 67 |
| | 1900 - 226 | 226 | 8 | 45 | 23 | 26 | 28 | 38 | 48 | 58 | 68 |
| | 1900 - 227 | 227 | 9 | 45 | 24 | 27 | 29 | 39 | 49 | 59 | 69 |
| | 1900 - 228 | 228 | 10 | 45 | 25 | 28 | 30 | 40 | 50 | 60 | 70 |
| | 1900 - 230 | 230 | 12 | 45 | 27 | 30 | 32 | 42 | 52 | 62 | 72 |
| | 1900 - 234 | 234 | 16 | 45 | 31 | 34 | 36 | 46 | 56 | 66 | 76 |
| | 1900 - 235 | 235 | 17 | 45 | 32 | 35 | 37 | 47 | 57 | 67 | 77 |
| | 1900 - 236 | 236 | 18 | 45 | 33 | 36 | 38 | 48 | 58 | 68 | 78 |
| 1900 - 242 | 242 | 24 | 45 | 39 | 42 | 44 | 54 | 64 | 74 | 84 | |
| 1900 - 244 | 244 | 26 | 45 | 41 | 44 | 46 | 56 | 66 | 76 | 86 | |

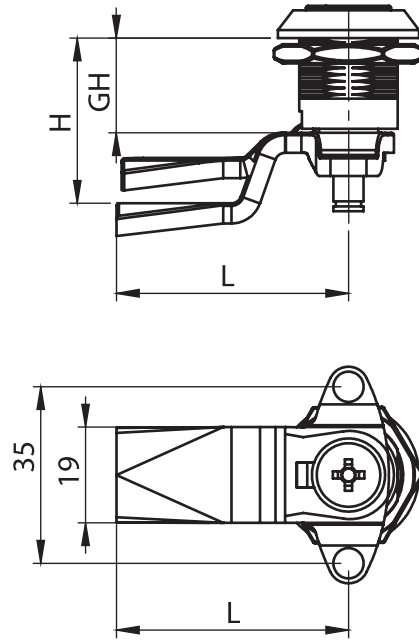

| Table 6 | Item Number | XXX | CH (mm) | L (mm) | GH=15 H(mm) | GH=18 H(mm) | GH=20 H(mm) | GH=30 H(mm) | GH=40 H(mm) | GH=50 H(mm) | GH=60 H(mm) |
|---------|-------------|-----|---------|--------|-------------|-------------|-------------|-------------|-------------|-------------|-------------|
| | 1900 - 418 | 418 | 0 | 45 | 15 | 18 | 20 | 30 | 40 | 50 | 60 |
| | 1900 - 420 | 420 | 2 | 45 | 17 | 20 | 22 | 32 | 42 | 52 | 62 |
| | 1900 - 422 | 422 | 4 | 45 | 19 | 22 | 24 | 34 | 44 | 54 | 64 |
| | 1900 - 424 | 424 | 6 | 45 | 21 | 24 | 26 | 36 | 46 | 56 | 66 |
| | 1900 - 425 | 425 | 7 | 45 | 22 | 25 | 27 | 37 | 47 | 57 | 67 |
| | 1900 - 426 | 426 | 8 | 45 | 23 | 26 | 28 | 38 | 48 | 58 | 68 |
| | 1900 - 428 | 428 | 10 | 45 | 25 | 28 | 30 | 40 | 50 | 60 | 70 |
| | 1900 - 430 | 430 | 12 | 45 | 27 | 30 | 32 | 42 | 52 | 62 | 72 |
| | 1900 - 432 | 432 | 14 | 45 | 29 | 32 | 34 | 44 | 54 | 64 | 74 |

| Table 7 | Item Number | XXX | CH (mm) | L (mm) | GH=20 H(mm) |
|---------|-------------|-----|---------|--------|-------------|
| | 1900 - 801 | 801 | 0 | 53,5 | 20 |
| | 1900 - 802 | 802 | 0 | 85 | 20 |
| | 1900 - 803 | 803 | 1 | 53,5 | 21 |
| | 1900 - 804 | 804 | 6 | 63 | 26 |
| | 1900 - 805 | 805 | 13,5 | 76 | 33,5 |
| | 1900 - 806 | 806 | 8 | 50 | 28 |

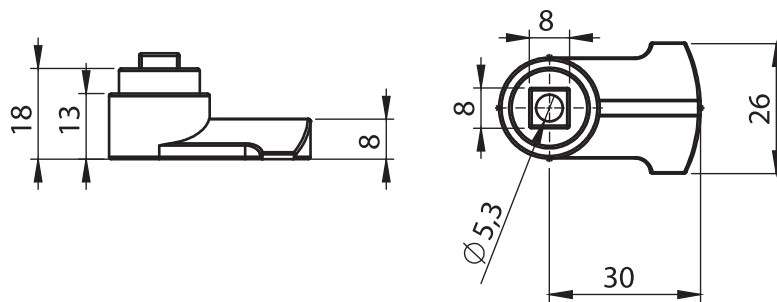

Material
Zinc Die, Raw

1900-605 - H=25 mm Metal Cam

| | |
|-------------|----------|
| Item Number | 1900-605 |
|-------------|----------|